

B-Series MURPHYGAGE®

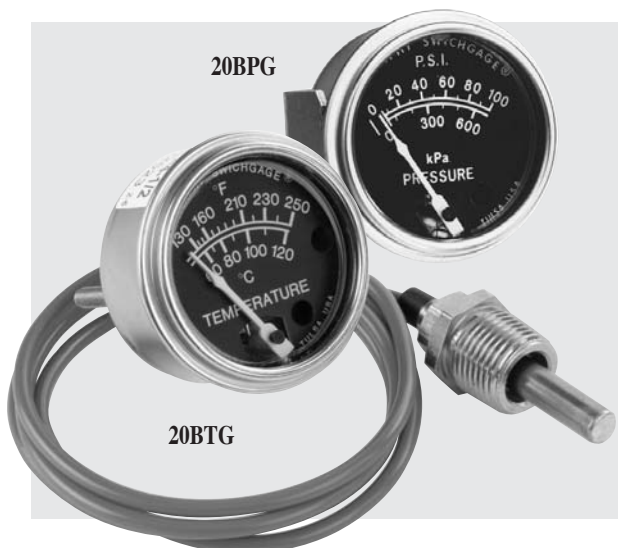

Pressure, Vacuum and Temperature

- 2 in. (51 mm) Dial Gages
- Heavy-duty Rated
- Environment Sealed*
- Pressure Models Up to 400 psi (2.76 MPa) [27.6 bar]
- Temperature Models Up to 440°F (220°C)



Description

The B-Series MURPHYGAGE® is a high quality, diaphragm-actuated indicating gage. Built by Murphy with the same heavy-duty design as the standard 20 series and 25 series SWICHGAGE®, the B-gage is more compact and is the optimum instrument for gage-only applications. It has a high impact polycarbonate lens, sturdy steel case, and a polished, low-profile stainless steel bezel. Accuracy and protection from moderate over-pressure/over-temperature are assured by a unique, unitized diaphragm chamber, superior quality materials, and the design of the gage movement.

Pressure MURPHYGAGE®

Pressure changes at the diaphragm convert to accurate mechanical movements that are indicated on an easy to read analog dial. A pulsation dampener in the pressure port helps eliminate pointer flutter; it can be removed for cleaning to maintain the MURPHYGAGE® response and accuracy.

Vacuum MURPHYGAGE®

Operating like the pressure MURPHYGAGE®, the vacuum instrument is available in 0 to 20 or 0 to 30 in. Hg. (0 to -68 or 0 to -102 kPa) vacuum.

Temperature MURPHYGAGE®

The temperature MURPHYGAGE® operates on the same mechanical principle as the pressure instrument. As temperature rises, the fluid in the sensing bulb vaporizes to apply pressure on the diaphragm; the movement translates this vapor pressure to a calibrated reading of temperature on the dial. The standard capillary is copper with a PVC armor. Optional armor covering is galvanized steel or 316 stainless steel (specify). Optional bulb types, adaptor nuts and thermowells are available. †

Applications

Industrial engines and equipment in Oil Field, Marine, Irrigation, Construction and Trucking industries. Monitoring Engine Coolant, Crankcase Oil, Transmission Oil.

Specifications

Dial: White on black; U.S.A. standard scale is dual scale; others available (see How to Order).

Gage Accuracy:

Pressure/Vacuum (% of Full Scale):

RANGE	LOWER 1/4	MIDDLE 1/2	UPPER 1/4
≤300 psi (24 Bar)	±3%	±2%	±3%
400 psi (28 Bar)	±3%	±3%	±5%

Temperature: See chart on reverse side.

Temperature Range:

Pressure/Vacuum:

Ambient: -40°F (-40°C) thru 150°F (66°C).

Process: -40°F (-40°C) thru 250°F (121°C).

Temperature: See chart on reverse side.

Maximum Panel Thickness: 1/4 in. (6 mm).

Port: Brass.

Case: Plated steel; mounting clamp included (except for direct mount models).

Bezel: Polished stainless steel, standard; optional bezels are available (see How to Order).

Pointer: White (black dial); black (white dial).

Lens: Polycarbonate, high-impact.

Sensing Element: Beryllium copper diaphragm.

Comparison of a MURPHYGAGE® to Most Other Gages

The basic difference between the MURPHYGAGE® and most other gages is the internal design. The MURPHYGAGE® does not rely on the gage case to serve as part of the sensing chamber. The diaphragm (A) which must expand and contract consistently with changing pressures and temperatures, is held firmly in place by the back plate (B) and the mounting plate (C). In most other gages the diaphragm (D) and an expansion retarding plate (E) are soldered directly into the case port and held in place by a locator ring (F). Should the case receive any damage

in this area the diaphragm operation could be affected. However, in the MURPHYGAGE®, the diaphragm is protected and securely locked in position. Another feature of the MURPHYGAGE® is the removable pulsation dampener (pressure instruments only) (G) which provides for periodic cleaning when being used with liquids which might cause clogging. Other gages are usually equipped with a non-removable dampener (H).

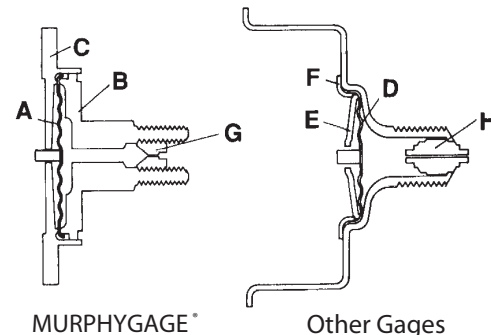

Warranty

A limited warranty on materials and workmanship is given with this FW Murphy product. A copy of the warranty may be viewed or printed by going to www.fwmurphy.com/support/warranty.htm

* All pressure gages, above 30 psi (200 kPa) [20.0 bar] and all temperature gages, are environmentally sealed and filled with inert gas. This seal protects the mechanism and eliminates "clouding" of the lens from moisture condensation.

** Products covered by this bulletin comply with EMC Council directive 89/336/EEC regarding electromagnetic compatibility except as noted.

† For optional temperature capillary lengths, engine adaptors, sensing bulbs and range combinations, see Murphy bulletin T-8428B.

Call MurCal To Place Your Order



Standard Dimensions

Pressure/Vacuum

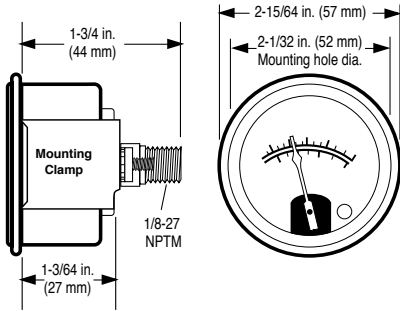

†Standard combinations. See Murphy bulletin T-8428B for optional sensing bulb, engine adaptors and capillary combinations.

Temperature

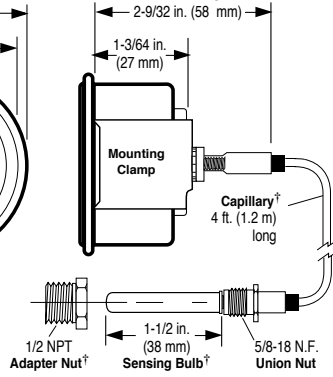

Temperature Accuracy/Range Chart

Celsius measurements are shown in parenthesis.

RANGE	Lower 1/3 Scale	Middle 1/3	Upper 1/3
32-120 (0-49)	± 12° (± 6)	± 5° (± 2.4°)	± 6° (± 3°)
32-160 (0-71)	± 20° (± 10°)	± 8° (± 4.4°)	± 7° (± 4°)
130-220 (54-104)	± 6°F (± 3°)	± 3° (± 1.6°)	± 4° (± 2°)
130-250 (54-121)	± 9° (± 5°)	± 5° (± 2.4°)	± 4° (± 2°)
140-300 (60-149)	± 10° (± 5.2°)	± 6° (± 3°)	± 5° (± 2.4°)
160-320 (71-160)	± 10° (± 5.2°)	± 5° (± 2.4°)	± 5° (± 2.4°)
180-350 (82-177)	± 12° (± 6°)	± 5° (± 2.4°)	± 5° (± 2.4°)
300-440 (149-227)	± 9° (± 5°)	± 5° (± 2.4°)	± 4° (± 2°)

MAXIMUM PROCESS TEMPERATURE

RANGE	MAXIMUM PROCESS TEMPERATURE
≤250° (120°)	120% OF FULL SCALE
300° (140°)	350° (198°)
≤320° (160°)	120% OF FULL SCALE

How to Order

To order, use the diagram below. **NOTE:** List options in ascending alphabetical order (A-Z). Example: **20BTG-IP1-250-4**

Base Model
20BPG = Pressure
20BVG = Vacuum
20BTG = Temperature

Options *
B1 = Black bezel
B2 = Bezel 05051857 (was "HP")
B3 = Bezel 05051836 (was "HBB")
D = Direct mount
IP1 = Light pipe illumination, 12 VDC
IP2 = Light pipe illumination, 24 VDC
* Options not available on all models or configurations.

Temperature Capillary Armor Type and Length

Capillary Armor Type

Blank = PVC armor, copper capillary
S = Stainless steel armor, copper capillary

Capillary Length (specify after capillary type; example: "S4")

4 = 4 ft. (1.2 m)
Specify other length = Available in 2 ft. increments thru 20 ft.; 5 ft. increments above 20 ft. (0.5 metre increments from 1.5-10 metres; 2 metre increments thru 34 metres. Specify "M" following length, i.e. 1.5M.)

Adapter Nuts^{†††}

1/8 = 1/8-27 NPT
1/4 = 1/4-18 NPT
3/8 = 3/8-18 NPT
3/8B = 3/8-19 BSPT
3/8K = 3/8 NPSF
- = 1/2-14 NPT ^{††††}
1/2B = 1/2-BSPT
1/2K = 1/2 NPSF
5/8 = 5/8-18 UNF
3/4 = 3/4-14 NPT
3/4U = 3/4-16 UNF
7/8 = 7/8-9 UNC

Metric

M10 = 10 mm x 1.5
M12 = 12 mm x 1.5
M14 = 14 mm x 1.5
M16 = 16 mm x 1.5
M18 = 18 mm x 1.5
M20 = 20 mm x 1.5
M22 = 22 mm x 1.5
M24 = 24 mm x 1.5

††† Specific adapter nut must match the sensing bulb.

†††† Standard.

Range^{††}

Pressure (20BPG) Dual scale (psi/kPa)	Pressure (20BPG) Single scale (bar)	Vacuum (20BVG) Dual scale (in. Hg/kPa)	Temperature (20BTG) Dual scale (°F/°C)	Temperature (20BTG) Single scale (°C)
psi kPa/MPa		in. Hg kPa	°F °C	
15 = 0-15 0-103	1B = 0-1 bar	20 = 0 to 20 0 to -68	120 = 32-120 0-49	70C = 0-70°C
30 = 0-30 0-207	2B = 0-2 bar	30 = 0 to 30 0 to -102	160 = 32-160 0-71	100C = 45-100°C
50 = 0-50 0-345	3.5B = 0-3.5 bar		220 = 130-220 54-104	120C = 50-120°C
75 = 0-75 0-517	5B = 0-5 bar		250 = 130-250 60-121	140C = 60-140°C
100 = 0-100 0-689	7B = 0-7 bar		300 = 140-300 60-149	160C = 70-160°C
150 = 0-150 0-1.03	10B = 0-10 bar		320 = 160-320 71-160	
200 = 0-200 0-1.38	14B = 0-14 bar		350 = 180-350 71-160	
300 = 0-300 0-2.07	20B = 0-20 bar		440 = 300-440 149-227	
400 = 0-400 0-2.76	28B = 0-28 bar			

†† Consult factory for availability of dials other than psi/kPa or °F/°C. Select scale so your normal operating value is in the middle half of the scale.

MURPHY

Call MurCal To Place Your Order

MurCal

(661) 272-4700 Fax: (661) 947-7570

www.murcal.com email: sales@murcal.com

