

Hydrostatic Head Level Switches



DF Series

- Salt Water Disposal Systems
- Cooling Towers
- Crude Oil Tanks
- Waterflood Systems
- Diesel Day Tanks
- Sumps



Description

The DF series are diaphragm operated “hydrostatic head pressure” level switches. A pressure sensitive diaphragm operates a snap-switch that can be wired directly to electric pilot circuits to control pumps at predetermined levels. Typical application is to start and stop electric driven pump(s) to maintain tank levels. It is also applicable to engine driven pumps.

The nitrile sensing diaphragm is impervious to most liquids and is sensitive enough to control levels with 1/4 in. (6 mm) repeatability. See model descriptions for limits of switch trip point adjustability. Materials include aluminum body, nylon bottom plate and a special alloy leaf snap-switch as standard.

This simple level switch is highly reliable and can be worked into almost any new or existing system without major modification or special tools.

DF755 and DF757 are suitable for atmospheric tanks in a non-hazardous area. The SPDT snap-switch for the DF755 is preset for a 4 in. (102 mm) differential in liquid level. The DF757 trip point is adjustable over a 108 in. (2743 mm) differential.

DF755EX is the same as the DF755 except CSA listed for Class I, Division 1, Groups C and D hazardous areas.

Applications

- Water Flood Systems
- Crude Oil Tanks
- Salt Water Disposal Systems
- Diesel Day Tanks
- Sumps
- Cooling Towers

Specifications

Snap-switch Ratings

SPDT (standard—all models)

- 5 A @ 125, 250, or 480 VAC
- 1/2 A @ 125 VDC, 1/4 A @ 250 VDC

DPDT (optional)

- 10 A @ 28 VDC
- 10 A @ 120, 230 VAC

Case/Lid: Aluminum (standard).

Bottom Plate: Glass-filled Nylon.

Process Connection: 1 NPT (standard).

Maximum Pressure Rating:
25 psi (172 kPa [1.72 Bar]).

Conduit Connection (electrical): 1/2 NPT.

Warranty

A limited warranty on materials and workmanship is given with this FW Murphy product. A copy of the warranty may be viewed or printed by going to www.fwmurphy.com/support/warranty.htm

*CSA listing applies to DF755EX 20 in. (508 mm) or less water column differential, 5A @ 125, 250, or 480 VAC.

**Products covered by this bulletin comply with EMC Council directive 89/336/EEC regarding electromagnetic compatibility except as noted.

Dimensions

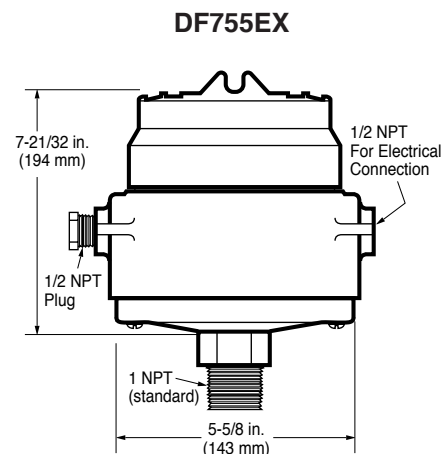
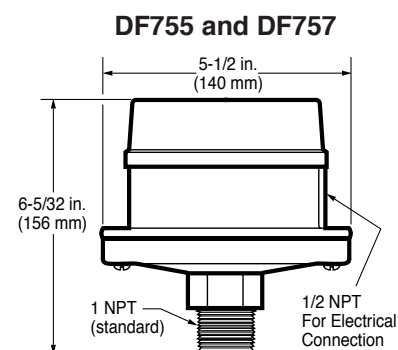

Call MurCal To Place Your Order

MurCal
(661) 272-4700 Fax: (661) 947-7570
www.murcal.com email: sales@murcal.com

MURPHY

Applications

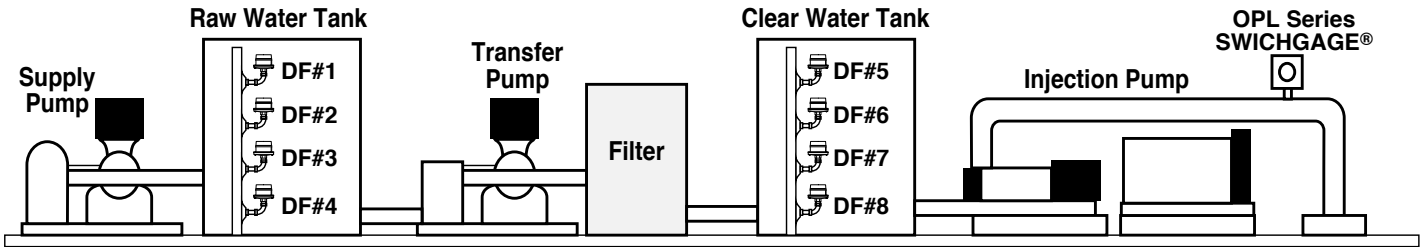

Typical Water Flood Control System

The diagram above displays eight DF Series switches installed on a Raw Water tank and a Clear Water tank. When raw water rises to predetermined level, **DF#1** stops the supply pump. As tank level falls below the predetermined level, **DF#2** starts the supply pump. If the tank level continues to fall, **DF#3** initiates shutdown of the supply pump. **DF#4** stops transfer pump before raw water tank is completely pumped out.

When clear water reaches the predetermined level, **DF#5** stops the

transfer pump. As tank level falls to predetermined low level, **DF#6** starts the transfer pump. If the tank level continues to fall due to the failure of the filters section, **DF#7** initiates shutdown of the transfer pump. (DF755 located at this level will also operate backwash equipment). **DF#8** stops injection pump before tank pumps completely out.

An OPL Series Pressure SWICHGAGE® stops injection pump when pressure reaches predetermined high or low pressure.

Tank with Low Pressure Gas Blanket (DF755EX)

The DF level switch (below) is shown installed on a crude oil tank where a low pressure gas blanket is used to prevent evaporation loss. It is mounted directly to the side of the tank or on riser pipe 4 to 7 in. (102 to 178 mm) below level to be controlled. Pump automatically stops or starts when liquid reaches predetermined high or low level.

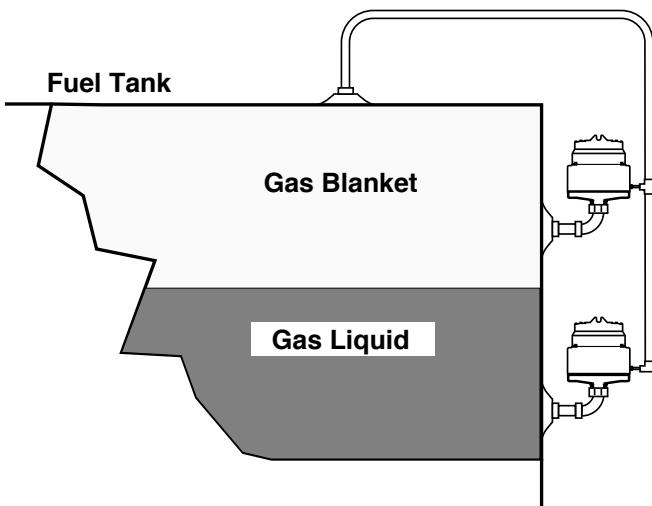

Typical Tank Mounting Methods (DF755)

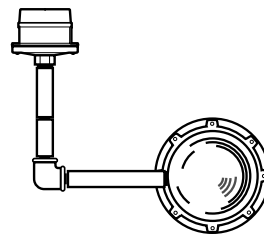

Bull Plug Installation

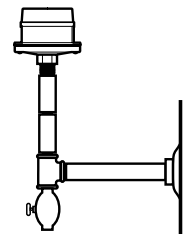

Tank Wall Mounting with Drain Cock

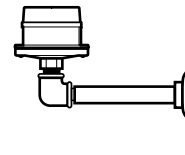

Tank Wall Mounting

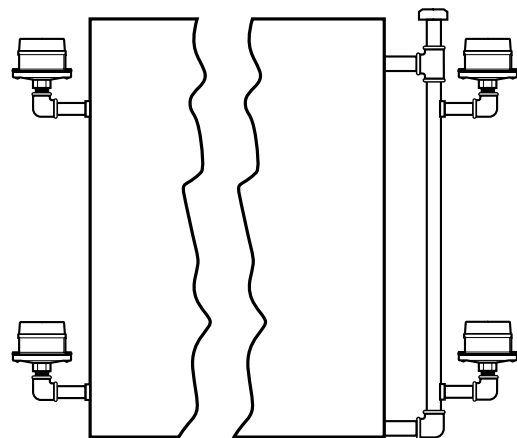

Directly on Tank

Riser Pipe Method

Basic Operation

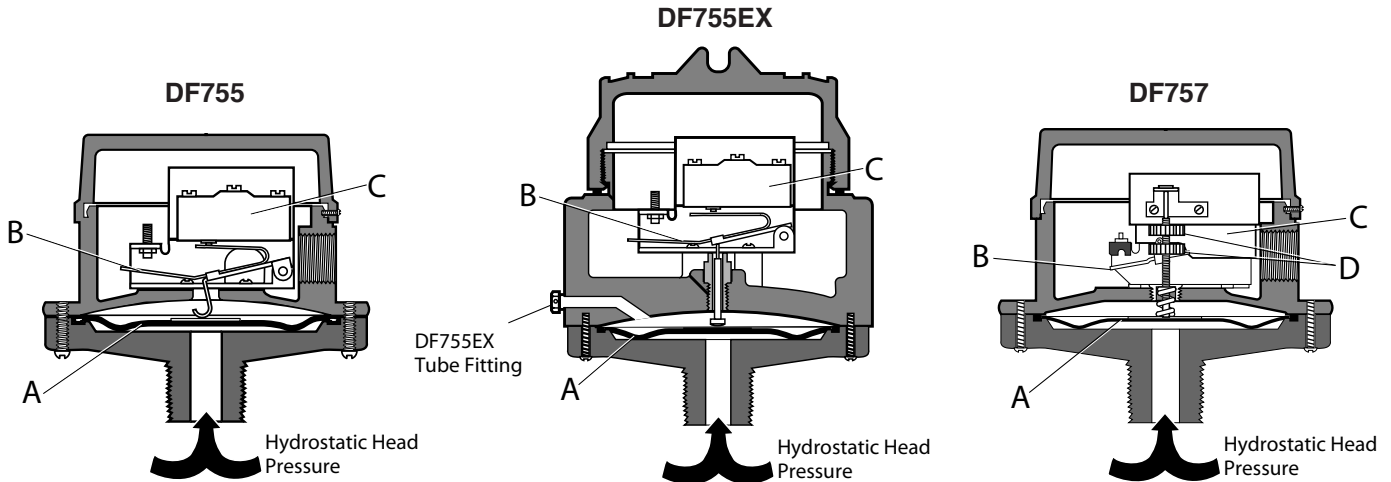

As the liquid level rises, hydrostatic head pressure is applied to the diaphragm A. The diaphragm is forced upward forcing the actuator arm B to activate the snap-switch C. Models DF755 and DF755EX are factory set and operate at approximately 2 in. (51 mm) and 6 in. (152 mm) above the level at which the diaphragm is mounted. The trip point(s) for Model DF757 are

adjustable between 2 in. (51 mm) and 110 in. (2794 mm) for high and low (make/break) operation by knobs, D. For sealed tanks, model DF755EX has a tube fitting to balance the top of the diaphragm chamber to a tank gas blanket (see Applications).

Typical Wiring

Starts at Low Level, Stops at High

Start motor when predetermined low level is reached and stop when high level is reached. Keeps tank level within selected limits. Motor starter equipped with H.O.A.

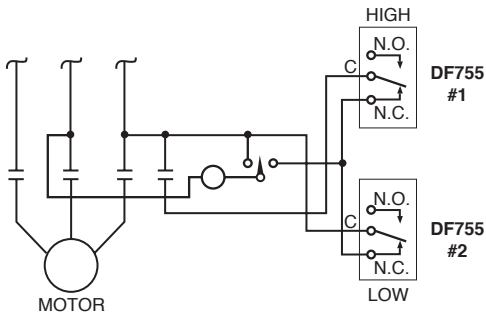

Starts at High Level, Stops at Low

Start motor when predetermined high level is reached and stop when low level is reached. Motor starter equipped with H.O.A.

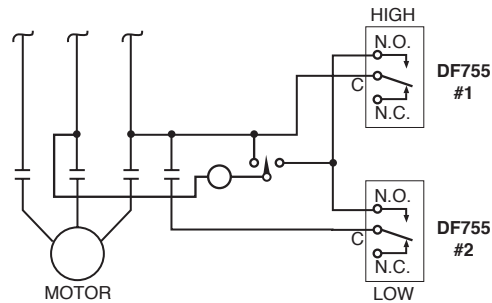

Single Magneto Shutdown

Shut down single ignition engine when fluid reaches low level. Simple wiring of magneto to N.O. switch terminal will shut down engine at predetermined high level, shown below.

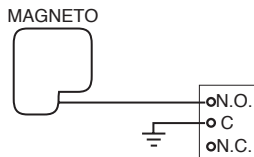

Dual Magneto Shutdown

Shut down dual magneto engines using Murphy MS2120 Magnetic Switch. Diagram below shows hookup for low level shutdown. Simple wiring changes and mounting locations are necessary for high level shutdowns.

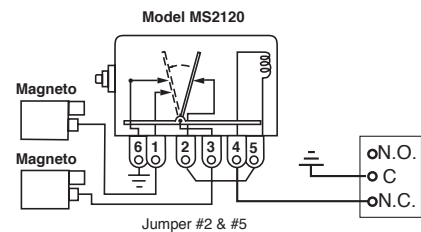

Accessories

Murphy offers the **MAC-1 Volume Air Cell** that can be attached to the DF755 to monitor water levels on a sump. Activates alarms or start a pump directly. The MAC-1 Volume Air Cell is non-corrosive and provides 1/4-20 stainless steel mounting studs.

The **MACT-1 Tubing Kit** provides 4 ft. (1.2 m) flexible, non-corrosive 1/4 in. (6 mm) tubing (cut to fit). The kit includes necessary fittings to attach tubing.

Volume Cell Operation

As liquid rises around the volume cell, it compresses air inside the cell and forces it up in the sensor line. As air pressure increases due to the water level continuing to rise, sufficient pressure will be applied to activate the internal snap-switch, which in turn starts the pump. As the liquid level is pumped down, pressure decreases and the above procedure is reversed. The pump is stopped and held in a standby condition. An air purge may be required in the sensor line. Consult factory.

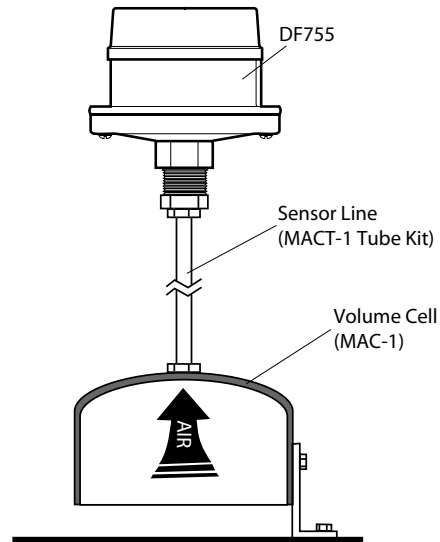

How to Order

To order the DF series, use the model number designation diagram below.

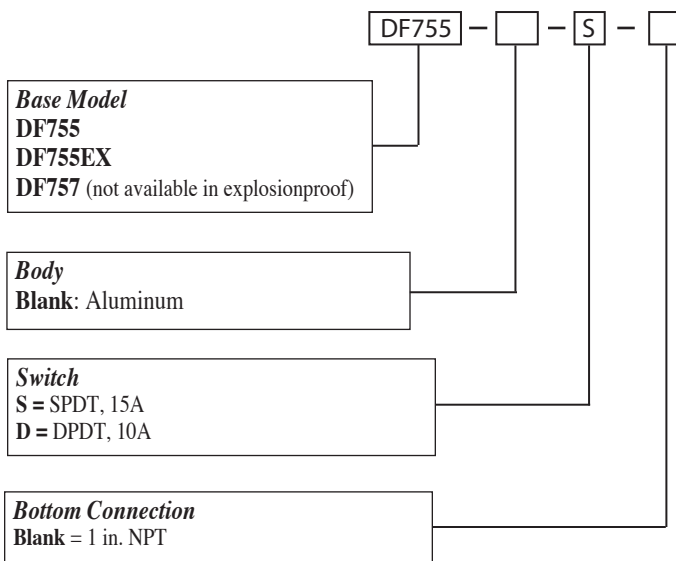

Accessories

The accessories below are sold separately and are available from Murphy.

Specify

MAC-1: air volume cell

MACT-1: air volume cell tube kit

Shipping Weights

DF755: 3 lb. (1.4 kg)

DF755EX: 6 lb. 9 oz. (3 kg)

DF757: 3 lb. (1.4 kg)

Shipping Dimensions

DF755, DF757, 6-1/4 x 6-1/4 x 6-1/4 in.

(159 x 159 x 159 mm)

Service Parts: DF Series

15000123 Diaphragm Repair Kit

Service Parts: DF755 Series

15000121 Snap-switch, and insulator assembly

15000122 Snap-switch, insulator and movement assembly

15000313 Movement and bracket assembly

Service Parts: DF757 Series

15000174 Snap-switch and bracket assembly



Call MurCal To Place Your Order



(661) 272-4700 Fax: (661) 947-7570

www.murcal.com email: sales@murcal.com

