

SWICHGAGE® Shutdown Panels for Irrigation Engines and Pumps

IR-03063B
Revised 10-03
Catalog Section 30
(00-02-0544)

MURPHY

75160 Series



- Ideal for Irrigation Engines
- Includes Loss of Pump Discharge Pressure and High Coolant Temperature SWICHGAGE® Instruments
- Model With Solenoid Fuel Shutoff Valve

Description

The 75160 series:

This SWICHGAGE® panel is specifically configured for irrigation engines and includes loss of pump discharge pressure SWICHGAGE®. The panel is enclosed on top, bottom, and both ends. Mounting flanges extend on top and bottom. The back of the panel is open. Access holes are in the bottom.

75160: includes low oil pressure, high coolant temperature, low pump pressure SWICHGAGE® instruments, Magnetic Switch, and emergency stop button.

75160D: includes SV-series solenoid diesel fuel valve (specify voltage).

For diesel engines without shut-down solenoid in the injection pump, add a Murphy SV Series solenoid fuel shut-off valve or RP2300 Series rack pull solenoid.

Panel Kits Include:

- Low Lube Oil Pressure SWICHGAGE®
- High Coolant/ Temperature SWICHGAGE®
- 518PH Magnetic Switch.
- SV Series Solenoid Fuel Shutoff Valve.
- PB128S Emergency stop push button.

Specifications

Low Lube Oil Pressure SWICHGAGE®:

- 0-100 psi (0-689 kPa) [0-6.89 bar]
- 1/8 NPT process connection

Low Pump Pressure SWICHGAGE®:

- 0-150 psi (1.03 MPa) [10.34 bar]
- 1/8 NPT process connection

High Coolant SWICHGAGE®:

- 130-250°F (54-121°C)
- 48 in. (1.2 m) capillary
- 1/2 NPT process connection

518PH Magnetic Switch:

12 or 24 volt (specify)

SV Series Solenoid Fuel Shutoff Valve:

12 or 24 volt (specify)

Shipping Weight: 8 lbs. 8 ozs. (3.9 kgs.)

Shipping Dimensions:

15.5 x 16 x 10.5 in. (394 x 406 x 267 mm).

Warranty

A limited warranty on materials and workmanship is given with this FW Murphy product. A copy of the warranty may be viewed or printed by going to www.fwmurphy.com/support/warranty.htm

Dimensions (all Models)

NOTE: This is an standard schematic. If non-standard components are specified, this schematic may not exactly reflect your panel.

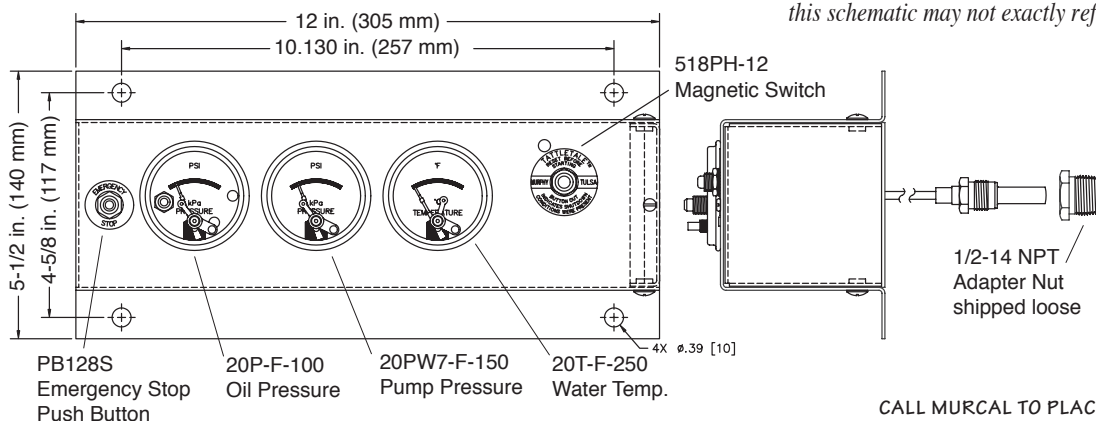

CALL MURCAL TO PLACE YOUR ORDER



How to Order

NOTES:

- * = Standard Component or Range and is not required for ordering, see section notes if section has two parts to specify.
- If requirements are outside of the matrix, order panel with free formed text and use the '3050xxxx' product number of the base model.

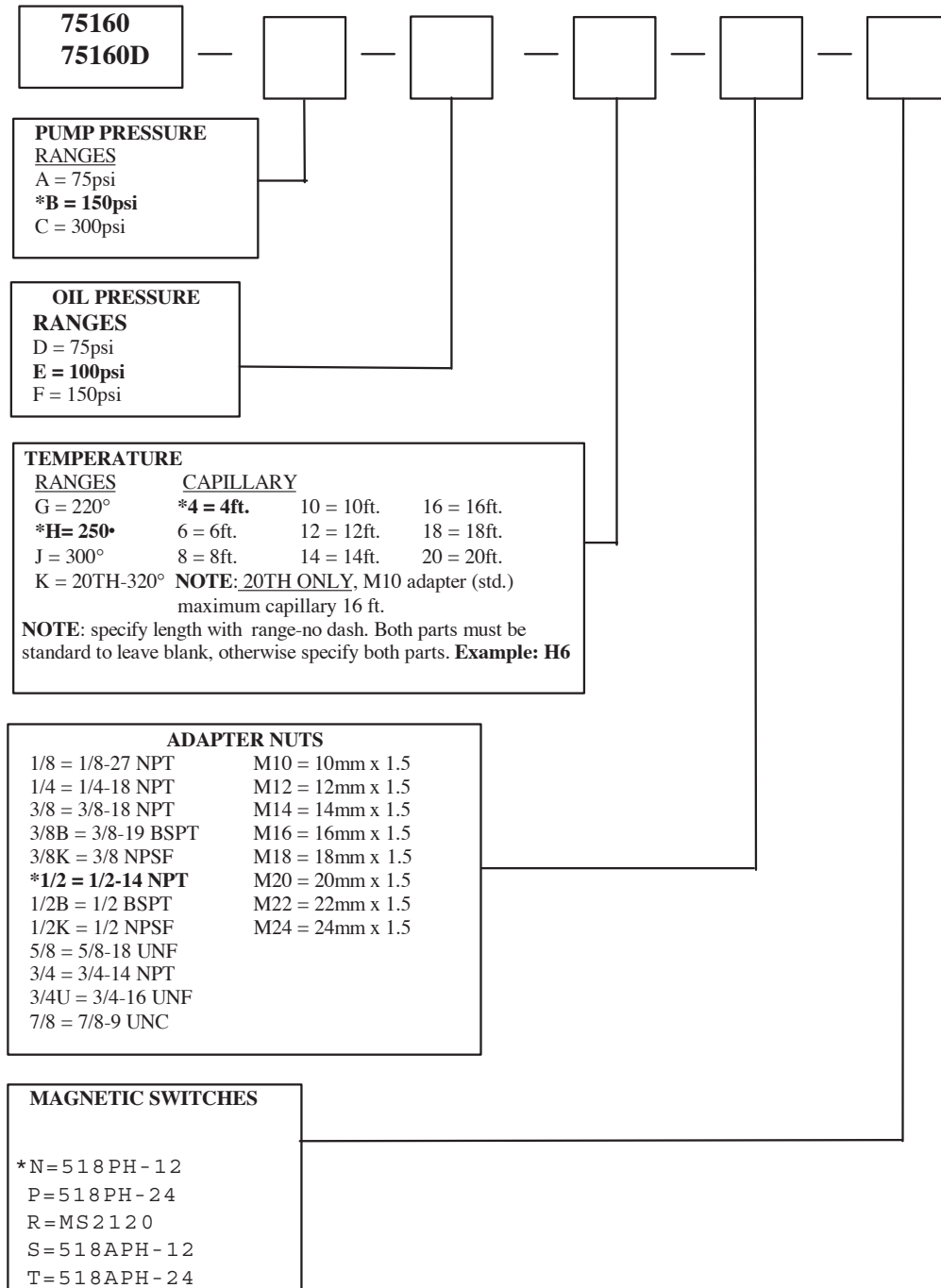

MURPHY

CALL MURCAL TO PLACE YOUR ORDER



P: (661) 272-4700 F: (661) 947-7570
 www.murcal.com e-mail: sales@murcal.com

