



CANdrive™ Module

Installation and Operations Manual

In order to consistently bring you the highest quality, full featured products, we reserve the right to change our specifications and designs at any time. The latest version of this manual can be found at www.fwmurphy.com.

Warranty - A two year warranty on materials and workmanship is given with this FW Murphy product. A copy of the warranty may be viewed or printed by going to www.fwmurphy.com/support/warranty.htm. In the event of a fault or technical query, please contact your Murphy representative for technical support.



Please read the following information before installing.

BEFORE BEGINNING INSTALLATION OF THIS MURPHY PRODUCT:

- A visual inspection of this product for damage during shipping is recommended before installation.
- It is your responsibility to ensure that qualified mechanical and electrical technicians install this product.
- Disconnect all electrical power to the machine.
- Make sure machine cannot operate during installation.
- Follow all safety warnings of the machine manufacturer.
- Read and follow all installation instructions.
- Please contact FW MURPHY immediately if you have any questions.

Table of Contents

General Information	1
Introduction	1
Installation Instructions	2
Configuration.....	2
Electrical Connection	3
Panel Mounting	5
Operation and Maintenance	6
Gage Driver Outputs	6
Indicating LEDs	6
Maintenance.....	7
Specifications	8
Power Supply	8
Inputs	8
Outputs.....	8
General	8

(THIS PAGE INTENTIONALLY LEFT BLANK)

General Information

Introduction

As part of the MurphyLink® family, the CANdrive™ offers a cost effective instrument solution for modern electronic engines. CANdrive acts as an interface between ECU CANbus/J1939 transmitted data and standard electric indicating gages. CANdrive and electric gages are an alternative solution to retrofitting of engine senders, magnetic pickups and associated wiring.

CANdrive has dedicated outputs for a tachometer, oil pressure, and coolant temperature electric gages. Configurable switch settings allow for selectivity between 12 or 24 VDC systems, and for all gage outputs to be selected for Murphy, VDO, or Datcon.

CANdrive is packaged in a compact, surface-mounted case with epoxy encapsulation for maximum durability and environmental sealing. Electrical connection is through a 12-way automotive-type connector.

Standard Model Options

Stock Code	Model / Description
78-70-0363	CDV100F , CAN drive J1939 to electric gage interface. 1 x CAN status LED, connector forward
78-70-0364	CDV300R , CANdrive J1939 to electric gage interface. 8 x status/fault LEDs, connector rearward. Model CDVG sealing gasket included.
78-00-0437	CDV-PW-30 , CANdrive power and CAN harness. Length: 30 in. (0.762m). Included with CDV100F and CDV300R

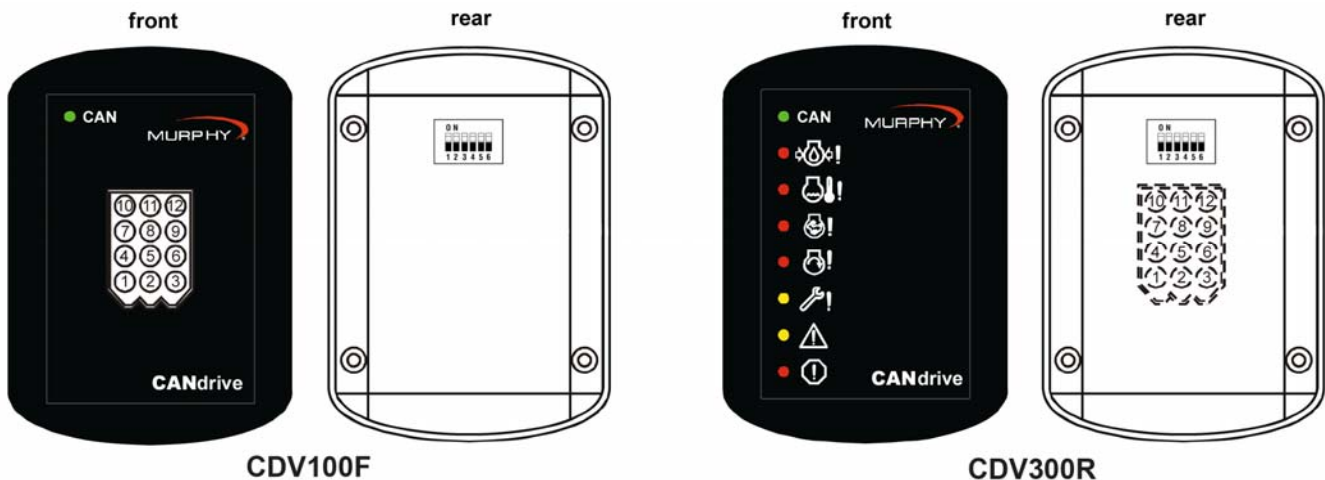

Installation Instructions

Configuration

CANdrive modules are supplied with configuration switches located on the back side of the unit. All switches are factory set to the ON (pushed up) position. Switches 1 to 5 allow configuration of CANdrive operating options. Switch 6 is not used.

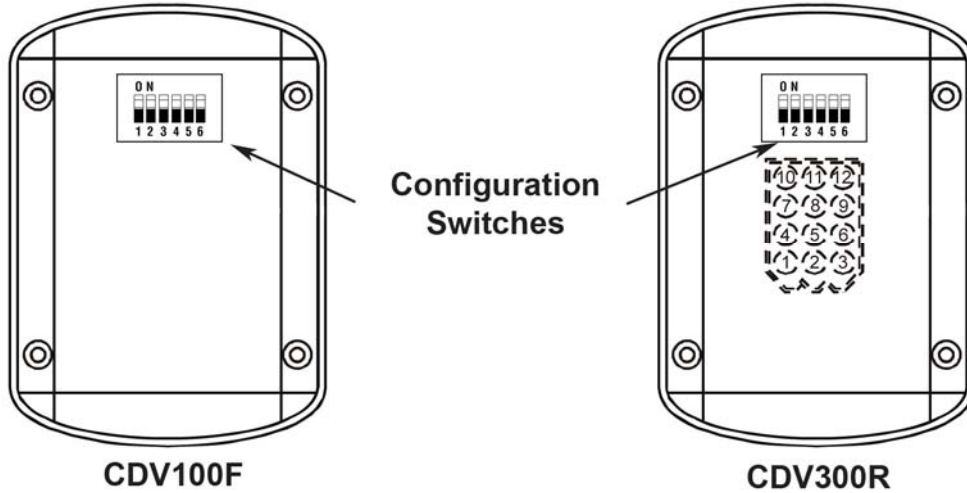

Configuration Table

Switch settings must be made according to the configuration table below.

Switch position		▲ on (up) ▼ off (down)			Options:
S1	S2	S3	S4	S5	
▲	▲	▲			Murphy temp. and pressure gauges
▼	▲	▲			Datcon temp. and 0 – 7 bar pressure gauges
▼	▲	▼			Datcon temp. and 0 – 10 bar pressure
▲	▼	▲			VDO temp. and 0 – 5 bar pressure gauges
▲	▼	▼			VDO temp. and 0 – 10 bar pressure gauges
			▲		CAN 120 Ohm terminating resistor in circuit
			▼		CAN 120 Ohm terminating resistor removed
				▲	12V DC power supply
				▼	24V DC power supply



WARNING: Adjustment of the switch positions must be made while CANdrive is powered down.

Gage Compatibility Tables

Pressure gauge compatibility table: pressure versus gauge equivalent sender resistance (Ohms)

Pressure	psi	0	10	20	30	40	50	60	70	80	90	100	110	120	130	140	150
	bar	0	0.7	1.4	2.1	2.8	3.4	4.1	4.8	5.5	6.2	6.9	7.6	8.3	9.0	9.7	10.3
Murphy		240	205	171	143	123	103	88	74	60	47	33					
Datcon		240	200	165	135	115	95	78	63	48	35	25					
VDO 0 – 7 bar		0	17	37	53	69	83	95	107	118	130	140					
VDO 0 –10 bar		10															184

Temperature gauge compatibility table: temperature versus gauge equivalent sender resistance (Ohms)

Temperature	°C	40	50	60	70	80	90	100	110	120	130	140
	°F	104	122	140	158	176	194	212	230	248	266	284
Murphy		1029	680	460	321	227	164	120	89	74	52	40
Datcon		900	600	400	278	200	141	104	74	50	27	4
VDO		282.4	190.0	134.0	95.2	69.1	51.2	38.5	29.4	22.7	18.0	14.5

Electrical Connection

CANdrive modules electrical connection is through a 12-way automotive type receptacle shown right. CANdrive models are available with the connector facing forward through the front label ('F' option, e.g. model CDV100F), or rearward through the epoxy encapsulation ('R' option, model CDV300R).

CANdrive electrical connection is through a 12-way automotive type receptacle. A 30-inch connector harness is included with each CANdrive model, and has each wire individually labeled for ease of installation.

Typical Connection

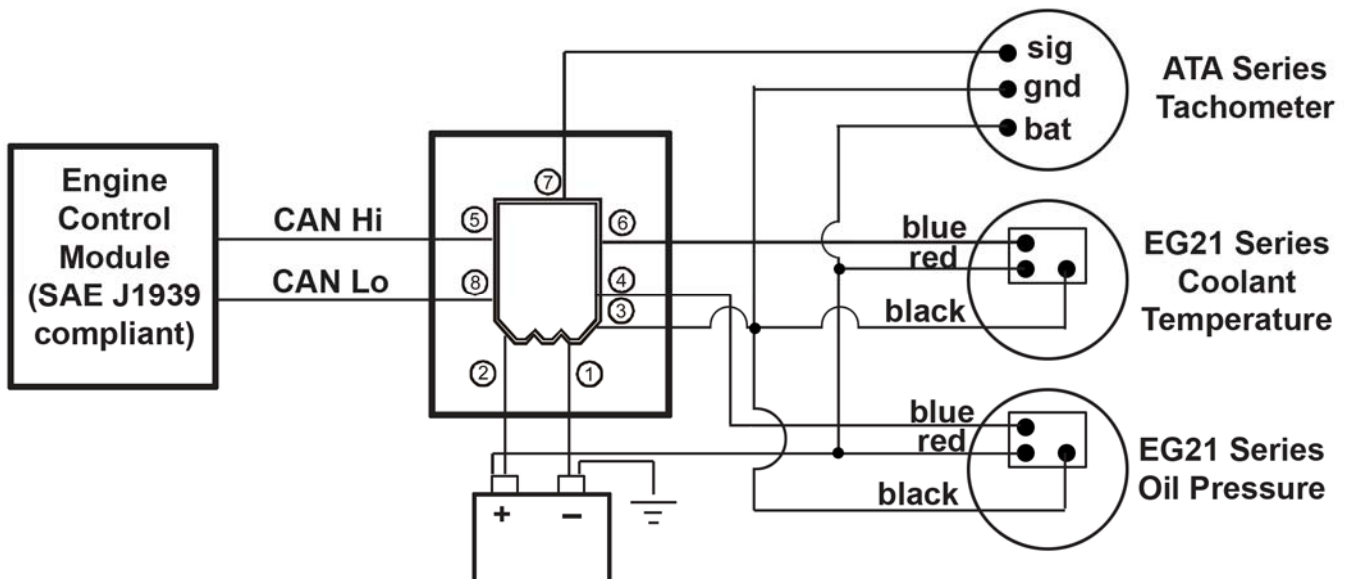

Terminal Functions

PIN	Function
1	Negative DC, power supply
2	Positive DC, power supply
3	Negative DC, gage common return CANdrive modules are supplied for use with 12V (7 to 16V) DC operation. If 24V (19 to 30V) DC operation is required, switch 5 must be pushed to the off (down) position. Connect a 1 Amp anti-surge fuse in the positive DC line (pin 2).
4	Oil pressure gage output
6	Coolant temperature gage output Pins 4 and 6 give a variable current output for driving oil pressure and coolant temperature electric gages. The outputs can operate with several different gauge types, according to the settings of switches 1, 2, and 3 - see Configuration section above.
7	Tachometer output Pin 7 gives a square wave output (0V to battery positive DC), with a frequency that is proportional to engine speed. At 1500 RPM engine speed, the output is approximately 121 Hz, suitable for driving charge alternator based tachometers such as the Murphy AT(H)A series. Pin 7 gives no output below 100 RPM engine speed. Connect each output to the appropriate gage/ tachometer signal input. Gage/tachometer negative terminals should be common to battery negative, ideally via dedicated wiring to terminal 3. (The use of dedicated return wiring to pin 3 rather than a ground return will minimize gage inaccuracies caused by ground noise.)
5	CAN Hi
8	CAN Lo Connect these terminals to the engine CANbus, taking care to observe the correct polarity. The CANbus cable screen/shield is typically connected to ground at the ECU end: refer to the engine manufacturer's installation guidelines. CANdrive modules are supplied with a 120 Ohm network terminating resistor fitted in-circuit between CAN Hi and CAN Lo. If CANdrive module is not positioned at the end of the CANbus network, remove the resistor by pushing switch 4 off (down).
9	Reserved for future use
10	Factory use
11	Factory use
12	Factory use

NOTE: Connection Pins 9, 10, 11, and 12 are reserved for future use, or are used in the factory setup of CANdrive modules. Do not connect wiring or equipment to these terminals. Connection can result in permanent damage to CANdrive modules.

Panel Mounting



WARNING: Do not install the CANdrive module near exhaust manifolds, turbochargers or other engine locations that might exceed the maximum allowable operating temperature of 185°F (85°C).

CANdrive modules are surface-mounted with four no. 4 screws, fixing center dimensions as shown. Select screw length according to panel thickness, ensuring a maximum of 1/2 inch (13mm) screw depth into the CANdrive module fixing holes.

Model CDV100F, with forward facing connector, is designed for surface-mounting inside an enclosed panel.

Model CDV300F, with additional LEDs and rearward facing connector, is designed for front-of-panel mounting: these modules require an additional 2.4" x 1.6" (60 x 40mm) cut-out for rear access to connector and switches. The CDV300F includes a CDVG gasket (fitted into a well behind the rim of the case) to provide front environmental sealing to IP65.

Rear view dimensions

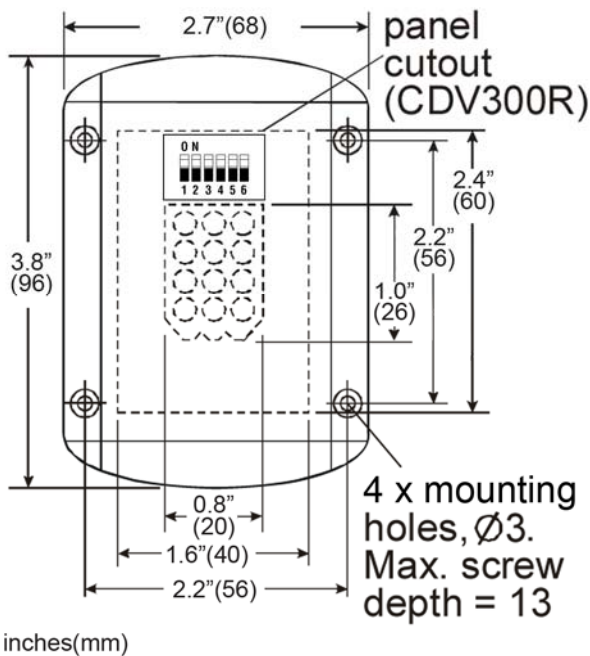

Before mounting, ensure that the final position allows access for:

- Connection of the included wire harness.
- Configuration of switches 1 - 5. Alternatively, set the switches before mounting. See Configuration section for full details.

Operation and Maintenance

Gage Driver Outputs







Gage outputs operate when CANdrive module reads valid J1939 data for engine speed, oil pressure and coolant temperature. If CANdrive module stops receiving valid data, the gage outputs are maintained at the last known value for approximately five seconds, after which time the outputs are turned off.

Indicating LEDs

All standard models have a green CAN status LED. A flashing CAN status LED indicates that CANdrive module is powered, but is not receiving any J1939 data. A constantly lit CAN status LED indicates a good CANbus connection and J1939 activity. (Note: J1939 activity can originate from ANY device on the CANbus network, and may not be valid data from the engine ECU.)

Model CDV300R has additional LEDs for indication of engine faults, as transmitted from the ECU. CANdrive modules respond to single DM1 (active fault code) messages that contain a Suspect Parameter Number (SPN), Fault Mode Indicator (FMI) and warning/stop lamp data. CANdrive modules also read multi-packet transport messages broadcast using the broadcast address message (BAM) protocol.

LEDs typically light continuously to indicate a shutdown fault, and flash to indicate a (non-shutdown) warning fault.

LED	Mode	Fault	J1939	
			SPN	FMI
	On	Low oil pressure shutdown	100	1
	Flashing	Low oil pressure warning	100	> 1
	On	Coolant temperature shutdown	110	0
	Flashing	Coolant temperature warning	110	> 0
	On	Overspeed shutdown	190	0
	Flashing	Overspeed warning	190	> 0
	-	Reserved for future use	-	-
	-	Reserved for future use	-	-
	Flashing	Warning fault	-	-
	Flashing	Shutdown fault	-	-

CANdrive modules can handle up to 8 simultaneous faults at one time; additional fault messages are not registered. When a fault becomes inactive and is no longer broadcast, the appropriate LED goes out after approximately two seconds.

Maintenance

CANdrive modules have no user-serviceable parts. Maintenance is therefore limited to the following preventative checks:

- Check that electrical connections are secure.
- Check that the CANdrive module is securely mounted and kept free from exposure to water or build up of excessive dust/dirt. The front label and casing may be wiped with a clean, damp cloth. Do not use cleaning solvents.

Specifications

Power Supply

- Operating voltage:
 - 12V range (switch S5 on/up) 7-16 VDC
 - 24V range (switch S5 off/down) 19-30 VDC
- Current consumption:
 - CDV100F: 25mA typical
 - CDV300R: 50mA, typical (2 LEDs lit)

Inputs

- CANbus:
 - SAE J1939 protocol, Input fitted with 120 Ohm terminating resistor, removable by switch 4.

Outputs

- Oil pressure gage, coolant temperature gage
 - Switch selectable for Murphy, VDO or Datcon electric gages
- Tachometer
 - Pulsed DC, approximately 121 Hz @ 1500 RPM

General

- Overall dimensions (W x H x D)
 - Case: 2.7x3.8x0.9 inch (68x96x22mm) (allow 2 inches (50mm) depth with connector)
- Weight: approximately .18 lbs (80g)
- Environmental sealing
 - IP60
 - CDV300R: IP65 from front with CDVG gasket (included)
- Operating ambient temperature: -40° F to 185° F (-40°C to +85°C)
- Storage temperature: -67°F to 221°F (-55°C to 105°C)
- Operating Vibration: .02 lbs (10g) (5-2000 Hz)
- Operating Shock: .11 lbs (50g) (3-axis)

MURPHY, the Murphy logo, and CANdrive are registered and/or common law trademarks of Murphy Industries, Inc. This document, including textual matter and illustrations, is copyright protected by Murphy Industries, Inc., with all rights reserved. (c) 2007 Murphy Industries, Inc. Other third party product or trade names referenced herein are the property of their respective owners and are used for identification purposes only.



CALL MURCAL TO PLACE YOUR ORDER



P:(661)272-4700 F:(661)947-7570
www.murcal.com e-mail: sales@murcal.com